

‘ENCORE’ SERIES SERVO AMPLIFIERS

MODEL 3000

USER MANUAL

ARCEE AUTOMATIONS
NO.32, BLOCK II, SIDCO COMPLEX,
GUINDY,
CHENNAI 600 032.

December 2009

INTRODUCTION

The 'Encore' Series amplifiers are second generation products designed for low cost and high performance. They are designed for edgewise mounting and can operate from power supplies ranging from 24V to 110V DC.

A wide range of inductive loads can be driven by the amplifiers. All models feature fully differential inputs for the control, or reference, voltage. Enable inputs for the control of outputs, and status signal and current monitor output are provided to ease system interfacing.

The 22 KHz switching frequency eliminates audible noise from the motor windings, and fast rise and fall times give high efficiency.

The amplifiers are protected against over temperature, over and under voltage, and short circuits between outputs, and from outputs to ground.

They are typically used as voltage to current converters. A +/- 10V signal will drive the amplifier's peak rated current to the load in the 'flat gain' mode. If a tachometer is used, the amplifier is still operated as a voltage to current converter, but DIP switch settings are changed to increase the gain of the servo amplifier.

Voltage mode operation with IR compensation is also supported and is switch selectable.

Loads driven are normally motors, but magnet coils, inductors or other non-motor loads can also be driven using appropriate settings.

THEORY OF OPERATION

AC voltage from the transformer is rectified and filtered to provide the DC bus voltage for the power stage. The power stage is a full bridge formed by power MOSFETs, and is capable of allowing the motor to accelerate or brake in either direction. The MOSFETs use separate floating power supplies for their gate drives, which allow the drive to operate without any restriction on the duty cycle.

The innermost control loop in the drive is a current control loop, the heart of which is a resistive feed-back element and the PWM control circuit. In the torque mode, the input signal is fed directly to the current loop and so the motor current is made equal to the input signal. The PWM circuit switches each leg of the bridge alternately to the bus voltage and to ground, to maintain the motor current at the desired value.

In the velocity mode, an outer loop is formed by comparing the tachometer's output voltage and the input signal. Thus, the motor's speed will equal the input signal. If the motor's speed varies due to load or voltage variations, the drive adjusts the motor current till the preset speed is again achieved. In the velocity mode, the tach, proportional, integral gains and integration time constant are all variable to allow tuning of the drive to varying load and speed conditions.

SALIENT FEATURES

MOSFET DRIVE FOR HIGH EFFICIENCY

Rugged power MOSFETs are used in the power stage. These have lower losses than comparable bipolar transistors, resulting in higher efficiency and also improved reliability due to lower temperatures. Also, MOSFETs have peak current ratings of approximately 10 times the average current, which makes them totally immune to spikes and surges.

ELECTRONIC SHORT CIRCUIT PROTECTION

An electronic circuit monitors the total supply current, and shuts off the voltage drive to each MOSFET if a predetermined limit is exceeded. This protects the output stage from direct shorts to either power rail as well as direct shorts across the armature terminals.

DIFFERENTIAL COMMAND INPUT

This provides high noise immunity, and is essential for proper operation in electrically noisy environments, and to eliminate switching noise picked up by the tach from integrated tach-motor packages.

AVERAGE CURRENT LIMITING FOR OVERLOAD PROTECTION

When the average current setting of the drive is exceeded, an analog timer starts. When the preset time limit is exceeded, the drive current is clamped to the set average value. This logic completely protects the motor from any overload damage.

VOLTAGE AND TEMPERATURE PROTECTION

The drive monitors logic and power supply voltages, as well as driver heat sink temperatures and shuts down the drive in the event the preset limits are exceeded.

FAULT OUTPUT

An open collector signal is available as an output from the drive, which can be set to activate either when the drive is in a normal state, or shut down due to a fault. This feature allows the signal to be used for driving a relay to be used for controlling a power fail brake mounted on the motor shaft, if required.

INTEGRATED HEATSINK AND COOLING FAN

An integrated heat sink with cooling fan is provided for reliable operation at high ambient temperatures. The cooling fan requires an external 220V AC supply.

TECHNICAL SPECIFICATIONS : MODEL ENCORE 3000

Typical specs at 25 degrees C, supply voltage = 110V DC, load = 0.25 mH + 2 ohms.

SUPPLY VOLTAGE

Minimum supply voltage	:	24 V DC
Typical operating supply voltage	:	110 V DC
Maximum operating supply voltage	:	120V DC
Typical Aux. Supply for cooling fan	:	220V AC 50Hz 0.2 Amps

OUTPUT POWER

Peak power output @ 50A, 110V (2 sec unipolar / 4 sec bipolar)	:	5500 W
Continuous power output @ 25A, 110V	:	2750 W

OUTPUT CURRENT

Peak output current @ $V_{out} = \pm 110V$ (2 sec unipolar / 4 sec bipolar)	:	$\pm 50A$
Continuous current @ 50 degrees C ambient	:	$\pm 25A$

OUTPUT VOLTAGE

$$V_{out} = V_{supply} - 0.12 * I_{out}$$

LOAD INDUCTANCE

Switch selectable in three ranges, 0.13 to 20 mH @ 75V, 0.25 to 40 mH @ 110V

SMALL SIGNAL BANDWIDTH

-3dB @ 3KHz

SWITCHING FREQUENCY

22 KHz

INPUT CHARACTERISTICS

Reference input	Differential, 90 K ohm min. between inputs
Max. input voltage	± 10 volts
Tachometer	Single ended, 21 K ohms
Max. tachometer input	± 30 volts
Input amplifier drift	0.05% per degree C

OVERCURRENT TIME LIMITS

The continuous current limit trimpot setting will affect the time limit at peak output currents as follows :

Continuous current setting	25A	17A	9A	
Time limit, Unidirectional change	2	1.5	1	sec
Time limit, Bidirectional change	4	3	2	sec

GAINS

Input differential amplifier	1.0
Servo preamplifier	Adjustable
Power amplifier stage	2 A/V
Current monitor	5.0 A/V

ADJUSTABLE SETTINGS

Trimpots : Peak current, Continuous current, Reference gain, Feedback, Tachometer gain, Balance, IR compensation.

DIP switches : Load inductance, Voltage feedback, Alternate compensation, Low gain, Flat gain, IR compensation, Normal polarity.

LED INDICATOR

Normal / Fault

Red / Green (Bicolour)

LOGIC INPUTS

 74HC levels, active low.

Enable -

Low enables amplifier

Pos Enable -

Low enables + output

Neg Enable -

Low enables – output

Reset -

Low resets fault

LOGIC OUTPUTS

Normal: Open drain MOSFET output, 100 mA / 50V

S8 open : Low when normal, High on fault condition

S8 closed : High when normal, Low on fault condition

Overcurrent

CMOS 5V output

AUXILIARY OUTPUTS

+/- 12 V

10 mA max.

PROTECTION FEATURES

Current v/s. time limiting

2 secs max @ +/-50A

Heatsink temp. limit

83 degrees C

Over-voltage shutdown

125V

Undervoltage shutdown

22 V

Output short circuit

Output-output, output-Ground

THERMAL REQUIREMENTS

Maximum ambient temperature

50 degrees C

Maximum power dissipation

80W @ +/- 25 Amps

MECHANICAL

Size without heatsink and cooling fan

55 x 240 x 155 mm

Size including heatsink and cooling fan

125 x 240 x 155 mm

Weight

2.0 Kgs

CONNECTORS : SIGNALS AND PINOUTS

Motor and power connections are made via a four terminal screw connector (P2).
Signal connections are made via a 15 pin 0.1” pitch connector (P1).

4 PIN POWER CONNECTOR P2

- PIN 1 : MOTOR OUT +, positive output
- PIN 2 : MOTOR OUT -, negative output
- PIN 3 : + HV RETURN (GND)and chassis ground
- PIN 4 : +HV, the high voltage DC power input.

15 PIN SIGNAL CONNECTOR P1

- PIN 1: +12V OUT, 10 mA MAX.
- PIN 2 : ENABLE-, ACTIVE LOW CMOS INPUT.
- PIN 3 : NEG ENABLE-, ACTIVE LOW CMOS INPUT.
- PIN 4 : POS ENABLE-, ACTIVE LOW CMOS INPUT.
- PIN 5 : RESET-, ACTIVE LOW CMOS INPUT.
- PIN 6 : NORMAL / FAULT OPEN COLLECTOR OUTPUT.
- PIN 7 : OVERCURRENT CMOS OUTPUT.
- PIN 8 : CURRENT MONITOR OUTPUT.
- PIN 9 : AUX INPUT.
- PIN 10 : SIGNAL GROUND.
- PIN 11 : -REF IN (DIFFERENTIAL INPUT).
- PIN 12 : + REF IN (DIFFERENTIAL INPUT).
- PIN 13 : SIGNAL GROUND.
- PIN 14 : TACH INPUT.
- PIN 15 : -12V OUT, 10 mA MAX.

GETTING STARTED

To install the amplifier you will require a control, or reference, voltage, a power supply, and a load. The reference voltage can be as simple as a potentiometer, or as complex as a digital control system. First you must determine the mode of operation, and the connect the amplifier to power supply, load and control system. Once installed, you will next power up and check that the motor, tachometer and control signal polarities are correct. The final operation is tuning, the process of adjusting amplifier gain, control system parameters, etc. to achieve the desired performance of the system.

OPERATING MODES

A mode is simply the way that the amplifier is used. Because the amplifier is one of the several components comprising a system, the operating mode frequently depends on the other components in the system. A tachometer is the most important option in determining the operating mode. If you use a tachometer, the amplifier will be

operating in the velocity mode. If no tachometer is used, typically you will be operating in the current mode. In both these modes, the amplifier operates as a current source, and the difference between them is in the setup of the servo preamplifier, the section between the PWM power stage and the input differential amplifier. The amplifier can also be operated as a voltage source. In this fashion, a given reference voltage will produce an output voltage that will remain constant over a range of output currents.

CURRENT MODE

Commonly used with microprocessor controls that use encoders for motion feedback and don't use tachometers. The amplifier acts as a wide bandwidth current source that puts out its peak current rating in response to a +/-10V reference voltage input. In this mode the servo preamplifier operates at low gain, and the PWM stage as a current source, changing the output voltage in order to maintain a constant output current.

VELOCITY MODE

Used with a tachometer. In this mode the amplifier continues to act as a wide bandwidth current source. The servo preamplifier operates at high gain, because it is amplifying the difference of the tachometer and the reference signal. The PWM stage again operates as a current source to accelerate / decelerate the motor to produce an RPM which makes the tachometer signal equal to the reference signal.

VOLTAGE MODE

This mode is used less frequently because it produces lower performance from the motor. As a voltage amplifier, an input voltage will produce an output voltage, which will remain relatively constant over a range of output currents. The servo preamplifier now amplifies the difference between the reference voltage, and the scaled down sample of the output voltage.

VOLTAGE MODE WITH IR COMPENSATION

This is a variation of voltage mode operation in which the servo preamplifier sees not only the reference and output voltages, but also the output current. Because the armature voltage (back emf, which produces the motor RPM) is the difference between the motor terminal voltage and the internal drop across the armature resistance, the it will decrease when greater loads produce greater currents. This current produces an "IR" drop (current x resistance = voltage) which subtracts from the terminal voltage of the amplifier. IR compensation mode increases the amplifier output when the load current increases. When adjusted correctly, the increase will just compensate the IR drop and the motor speed will remain constant without a tachometer. The actual regulation will not be as good as with a tach, but is simpler and cheaper than using a tach, and is adequate for many situations.

FRONT PANEL ADJUSTMENT TRIMPOTS

REF. GAIN : Attenuates the output of the reference signal gain differential amplifier. Fully CW will send the full reference signal to the servo preamplifier stage. CCW rotation will result in less reference signal sent to the preamp. This adjustment acts like an overall 'volume' control for the amplifier, controlling the amps-out per volt-in.

TACH. GAIN : Adjusts the tachometer scaling signal. When fully CW, a 10V reference signal will demand 10V from the tachometer. As this is adjusted CCW, the motor speed will increase. Use this to set the basic RPM-out to volts-in ratio of the amplifier.

FEEDBACK : Sets the gain of the servo preamplifier. Usually set to a minimum (fully CW) in current mode operation for maximum bandwidth. When using tachometers, turn this pot CCW until oscillation begins, and then back off 1 or 2 turns for stable operation. Adjustment of this pot affects the response of the amplifier to a step input.

BALANCE : Used to 'null' the output of the amplifier when the reference inputs are at 0 V. adjust the pot for zero current, or for zero volts between motor + and motor- when the input to the amplifier is zero.

PEAK CURRENT LIMIT : Controls the peak current the amplifier can output to the load. Fully CW the amplifier will drive the rated peak current. As this is turned CCW, the maximum current will gradually decrease. Useful for protecting mechanical parts when the maximum current required by the load is less than the amplifier's peak rating.

CONTINUOUS CURRENT LIMIT : Controls the continuous current that the amplifier can output to the load. Fully CW the amplifier will drive the rated continuous current. As this is turned CCW, the continuous current will gradually decrease. Useful for protecting motors such as printed-circuit and basket-wound motors that have high peak current but low continuous current ratings.

IR COMPENSATION : Used in voltage feedback mode with S3 and S7 on. Adjusts the amount of positive feedback from the current circuit. This feedback increases the output voltage when the load draws a higher current. Because it is positive feedback, too much of it can cause severe oscillation. When adjusted correctly the motor speed will remain constant as the load changes, without using a tachometer.

DIP SWITCHES

S1,S2 : LOAD INDUCTANCE SELECTOR. Set these two switches based on the inductance of the load and supply voltage.

S1	S2	at 75V	at 110V
On	On	0.13 to 0.75 mH	0.25 to 1.5 mH
Off	On	0.8 to 5 mH	1.6 to 10 mH
Off	Off	5.1 to 20 mH	10.1 to 40 mH

S3 : VOLTAGE FEEDBACK. No effect when off. When on this switch substitutes the output voltage divided by 25 in place of the tachometer, converting the amplifier from a current to a voltage amplifier. If the gain of 25 is too high, use the Ref. Gain trimpot to reduce the gain further.

S4 : ALTERNATE COMP. Typically the Ref. Gain pot will be set to fully CCW when using this feature. This switch connects the output of the reference gain differential amplifier to the Aux. Input internally. The servo preamp. Can then be customized for special applications.

S5, S6 : GAIN SETTING. Set the switches according to the chart below. They adjust the gain of the servo preamplifier.

S5	S6	Gain mode
On	On	Current mode
Off	Off	Velocity mode
Off	On	Medium Gain mode

S7 : IR COMPENSATION . Enables feedback from the current monitor when on. This mode is an option when operating in voltage mode. IR compensation increases the output voltage to compensate for the voltage drop across the motor's armature resistance. Normally this drop would decrease the motor's RPM under cahnging load conditions. IR compensation permits a relatively constant velocity operation without a tachometer.

S8 : NORMAL POLARITY . This switch changes the polarity of the Normal / Fault output. With S8 off, a normal condition turns the output On. When S8 is On, the logic is reversed and a fault condition turns the output On.

CONNECTING THE AMP IN CURRENT MODE (NO TACHOMETER)

Use this checklist for applications that don't require a tachometer. These include control systems that get their feedback from an encoder, as well as non-motor applications that require a set current from the amplifier in response to the control voltage at the input.

1. Connect DC power supply to the amplifier HV and ground.
2. Ground the amplifier chassis at P2-3.
3. Connect motor or load between OUT+(P2-1) and OUT-(P2-2).
4. Connect a reference voltage source between REF+ and REF- inputs.
5. Ground ENABLE, POS ENABLE and NEG ENABLE signals to logic ground.
6. Set DIP switches S1, S2 for motor inductance.
7. Set DIP switches S3, S4, S7 OFF and set S5, S6 ON.
8. Set REF GAIN pot to full CW.
9. Set FEEDBACK pot to full CCW.
10. Set PEAK CURRENT LIMIT pot to half CW.
11. Set CONT CURRENT LIMIT pot to half CW.
12. Set TACH GAIN pot to full CW.
13. Set IR COMP pot to full CCW.
14. Set VREF to zero volts.
15. Turn power on.
16. Check for green LED indicating normal operation.
17. Set BALANCE pot for zero volts between OUT+ and OUT -.
18. Momentarily increase reference voltage.
19. Check motor direction : is it OK ? If yes, proceed else power off, reverse OUT+ and OUT-, and power on again.
20. Set reference voltage to maximum value (+/-10V).
21. Check load current at CURRENT MONITOR output, or by using an ammeter in series with the load.
22. Adjust PEAK and CONT current limit to the desired values.

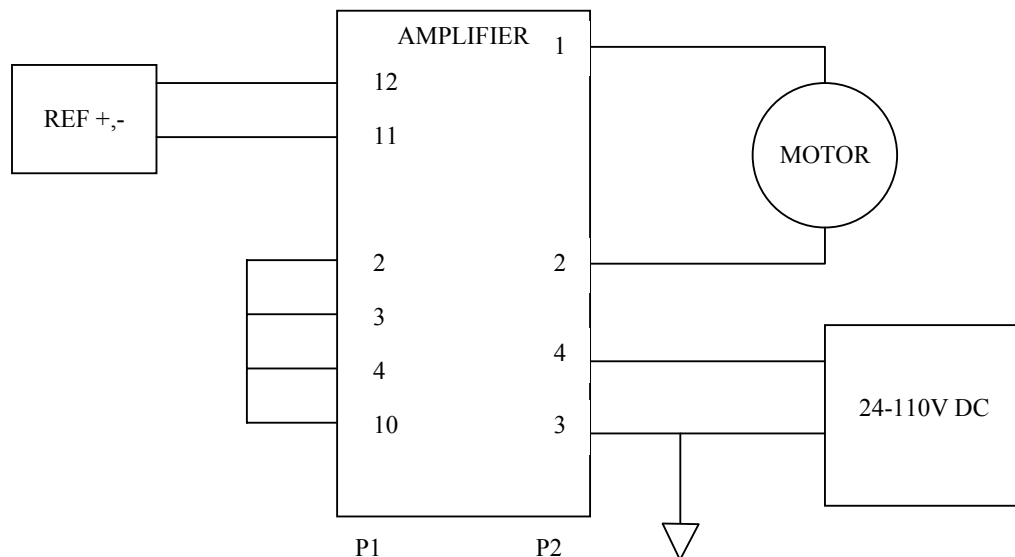

CONNECTING THE AMP IN VELOCITY MODE (WITH TACHOMETER)

Use this checklist for applications that require velocity mode and a tachometer.

1. Connect DC power supply to the amplifier HV and ground.
2. Ground the amplifier chassis at P2-3.
3. Connect motor or load between OUT+(P2-1) and OUT-(P2-2).
4. Connect tachometer between tach input and signal ground.
5. Connect a reference voltage source between REF+ and REF- inputs.
6. Ground ENABLE, POS ENABLE and NEG ENABLE signals to logic ground.
7. Set DIP switches S1, S2 for motor inductance.
8. Set DIP switches S3, S4, S5, S6, S7 OFF.
9. Set REF GAIN pot to full CW.
10. Set FEEDBACK pot to full CCW.
11. Set PEAK CURRENT LIMIT pot to half CW.
12. Set CONT CURRENT LIMIT pot to half CW.
13. Set TACH GAIN pot to full CW.
14. Set IR COMP pot to full CCW.
15. Set VREF to zero volts.
16. Turn power on.
17. Check for green LED indicating normal operation.
18. Does motor run away ? If yes, power off. reverse tach leads and power on.
19. Set BALANCE pot for zero volts between OUT+ and OUT -.
20. If oscillation occurs, turn FEEDBACK CW till it stops.
21. Momentarily increase reference voltage.
22. Check motor direction : is it OK ? If yes, proceed else power off, reverse OUT+ and OUT- and tach leads, and power on again.
23. Set reference voltage to maximum value (+/-10V).
24. Set TACH gain till desired RPM is reached.
25. Check load current at CURRENT MONITOR output, or by using an ammeter.
26. Adjust PEAK and CONT current limit to the desired values.
27. If oscillation occurs under varying input conditions, re-adjust FEEDBACK pot.

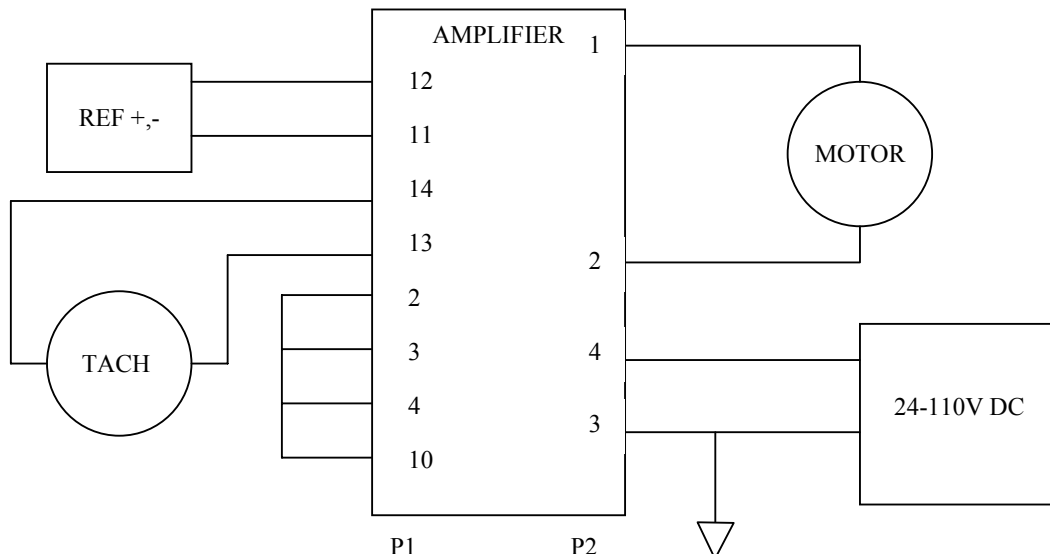

CONNECTING THE AMP IN VOLTAGE MODE

Use this checklist for applications that require velocity mode but no tachometer. IR comp can be used to greatly improve the speed regulation.

1. Connect DC power supply to the amplifier HV and ground.
2. Ground the amplifier chassis at P2-3.
3. Connect motor or load between OUT+(P2-1) and OUT-(P2-2).
4. Connect a reference voltage source between REF+ and REF- inputs.
5. Ground ENABLE, POS ENABLE and NEG ENABLE signals to logic ground.
6. Set DIP switches S1, S2 for motor inductance.
7. Set DIP switches S4, S5, S6, OFF. Set S3 ON, also S7 if using IR COMP.
8. Set REF GAIN pot to full CW.
9. Set FEEDBACK pot to full CCW.
10. Set PEAK CURRENT LIMIT pot to half CW.
11. Set CONT CURRENT LIMIT pot to half CW.
12. Set TACH GAIN pot to full CW.
13. Set IR COMP pot to full CCW.
14. Set VREF to zero volts.
15. Turn power on.
16. Check for green LED indicating normal operation.
17. Set BALANCE pot for zero volts between OUT+ and OUT -.
18. If oscillation occurs, turn FEEDBACK CW till it stops.
19. Momentarily increase reference voltage.
20. Check motor direction : is it OK ? If yes, proceed else power off, reverse OUT+ and OUT- leads, and power on again.
21. Set reference voltage to half the maximum value (+/-5V).
22. Set TACH gain till desired no load RPM for max / 2 signal is reached.
23. Apply a load to the motor, and adjust IR comp till the old RPM is re-obtained.
24. Check load current at CURRENT MONITOR output, or by using an ammeter.
25. Adjust PEAK and CONT current limit to the desired values.
26. If oscillation occurs under varying input conditions, re-adjust FEEDBACK and / or IR COMP pots.

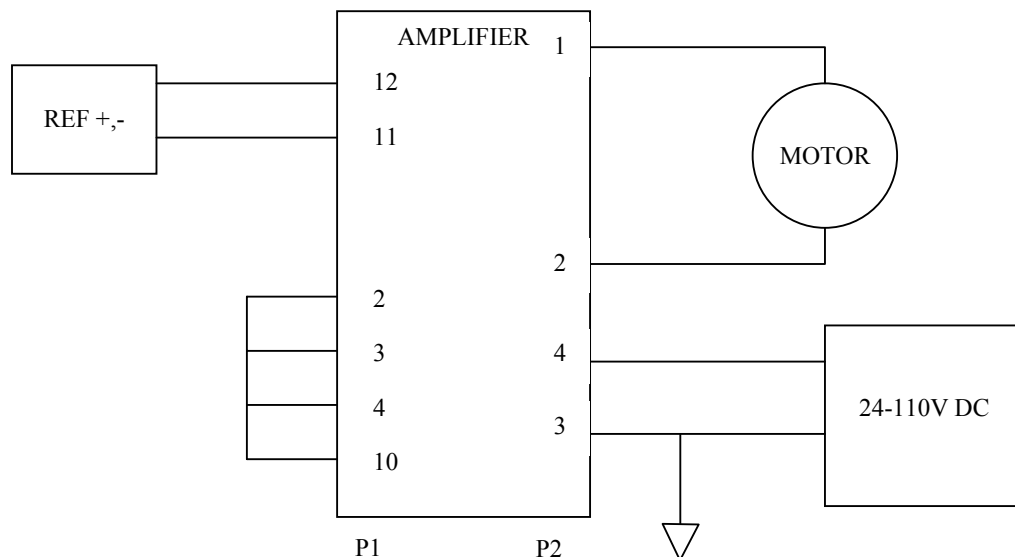

POWER SUPPLY AND WIRING CONSIDERATIONS

1. Make sure that the applied supply voltage is adequate to drive the motor at maximum current and maximum RPM. This should equal the maximum motor voltage on load, plus saturation losses in the amplifier and an extra 5 to 10 percent for ripple.
2. Under low input supply conditions, the voltage requirement of (1) may not be met, and this may be seen effectively as poor regulation at high speeds, since the amplifier may not have adequate 'headroom'.
3. When operating with low voltage supplies close to 24V, check the Normal LED while accelerating. If it goes off occasionally, it may be due to supply going below 22V while the motor draws accelerating current. In this case, filter capacitor value and / or supply voltage should be increased.
4. When operating with higher supply voltages close to 110V, check the Normal LED while decelerating. If it goes off occasionally, it may be due to the fact that the energy pumped back from the inertial load back to the power supply capacitor causes the supply to exceed 125V. In this case, reduce the power supply voltage, reduce the deceleration rate or install a regenerative brake. Contact factory for details of regenerative brake.
5. When connecting multiple amplifiers from the same supply, use a 'star' connection with supply wires to each amplifier going directly to the filter capacitor. Don't 'daisy chain' by looping power leads from one amplifier to the next. Connect P2-3 of each amplifier individually to chassis ground, and do not ground the - terminal of the filter capacitor.
6. Use wires of appropriate size for connecting power supply and main motor leads. Keep connecting conductors as short as possible, and avoid bundling these wires with any sensitive control signals, as they carry large switching currents.

LOAD INDUCTANCE

DIP switches S1 and S2 can be used to set the amplifier to compensate for a range of load inductances. The inductance range varies with applied voltage, and this should be taken into account if significantly lower supply voltages are used.

BANDWIDTH

The bandwidth of the amplifier is -3dB at 3 KHz and is defined for small signal operation. The effect of bandwidth is to limit the frequency of a sine wave that can be amplified, or to limit the rise time of a step input signal. The type of load will also have an effect on bandwidth, especially with increasing inductance. The factor V/L will be the limiting factor, as it defines the maximum rate of change of current.

ENABLE INPUTS

The enable inputs may be driven through relay contacts, NPN transistors or sensors, etc. The signals must be low (pulled to ground) to enable. The positive and negative enable signals can be used for selective enabling, for example in a linear system to cut off the drive at end-of-travel limits. For shutting off the entire amplifier, for example from a control system, use the Enable input.

NORMAL / FAULT OUTPUT

The Normal / Fault output polarity can be selected by DIP switch S8 as described earlier. It can be used to drive opto-couplers, lamps, relays etc. While driving relays, remember to install a fly-back diode in reverse across the relay coil to protect the Normal / Fault output MOSFET.

RESET INPUT

This signal can be grounded momentarily to reset a fault condition. DO NOT ground this input continuously. If a fault condition occurs and persists, it could cause overheating of the output stage of the amplifier.

NORMAL / FAULT LED

The LED is Red, indicating a fault, under any of the following conditions :

Supply voltage outside normal limits (22 to 125 volts).

Heatsink temperature is above 83 degrees C.

A short circuit exists between outputs, or between outputs and ground.

If none of the error conditions described above has occurred, the LED will be Green if the Enable input is low (true), or off if the Enable is high (false).

The short circuit and over temperature errors are latched, and can be cleared by cycling power off and on, or by pulsing the reset input low.

+/- 12 V SUPPLY OUTPUTS

These auxiliary supply outputs can supply a maximum current of 10 mA. If they are accidentally short circuited, power will have to be cycled off and then on again to restore normal operating conditions.

TROUBLESHOOTING GUIDE

Amplifier NORMAL light does not come on.

1. Check that at least between 24V and 110V DC is available at the amp's DC power input. Increase or decrease supply if outside these limits.
2. Check that the enable signal is low (active).

Amplifier FAULT light is always on.

1. Check for high temperature caused by failure of cooling fan or loss of 220V AC supply to cooling fan.
2. Check for possible short from motor wires to ground, or across motor wires.

NORMAL light goes off while accelerating.

1. Check for power supply dipping below 24V while motor accelerates. If this is happening, either increase supply voltage, increase filter capacitor or slow down the acceleration by adding a resistor in series and a capacitor to ground on the reference signal.
2. This problem can also be caused by noise on the input signal, or if the input reference is being switched by relays, etc. Check that the amplifier is properly earthed, and if necessary install an RC filter as described above.

NORMAL light goes off while decelerating.

1. Check for power supply going above 125V while motor accelerates. If this is happening, either reduce supply voltage, install a regenerative brake or slow down the deceleration by adding a resistor in series and a capacitor to ground on the reference signal.
2. This problem can also be caused by noise on the input signal, or if the input reference is being switched by relays, etc. Check that the amplifier is properly earthed, and if necessary install an RC filter as described above.

NORMAL light is on but motor does not run.

1. Check for proper input signal at the reference input.
2. Check for any break in motor wires.

NORMAL light is on but motor speed is uncontrolled.

1. Check for break in tach wires to the amplifier.

Oscillation or other instability in motor operation.

1. Check that amplifier is properly earthed.
2. Check for noise pickup on the input or tach signals. Try using RC filters or shielding these connections.
3. Check tuning of amplifier. Refer to procedures described earlier.

FEEDBACK
BALANCE
PEAK I
CONT I
IR COMP
TACH
REF GAIN
S1

S8
FLT/NORM
P1-15

P1-1
OUT +
OUT -
GND
HV

ENCORE

PWM SERVO AMPLIFIER